

# WIDDER TOOLS



## PI7000-01 Air Operated Hydraulic Pump



### *PRODUCT INFORMATION AND OPERATING INSTRUCTIONS*

**Description:** The **PI7000-01** Pump is a 95:1 ratio air driven hydraulic pump. This is the standard pump used in the **WIDDER HPIC** and **HPIM** Hydrostatic Test Units. This pump is also available in different configurations up to a 740:1 ratio capable of 65,000 PSI.

<b>Specifications:</b>	Ratio	95:1
	Max. Output Pressure	9,700 PSI
	Fluid Inlet	1/2" NPT
	Fluid Outlet	1/2" NPT
	Air Inlet	1/2" NPT
	Air Outlet	1" NPT
	Max. Air Input Pressure	100 PSI
	Max. Air Consumption	56 CFM @ 100 PSI (no load)

**IMPORTANT: READ MANUAL CAREFULLY BEFORE OPERATING THIS TOOL. FOLLOW ALL SAFETY PRECAUTIONS LISTED AND ALL OSHA REGULATIONS PERTAINING TO THIS TOOL.**

# PUMP INSTALLATION

## 1. MOUNTING THE PUMP

There are threaded holes in the bottom of the hydraulic cylinder for this purpose (see diagram below for details). The pump can be mounted in any position, but vertical mounting is preferred. If the pump must be mounted in the inverted position, a 1/16" diameter drain hole must be drilled in the top of the air motor head casting. This allows any accumulated liquid in the pilot valve air chamber to be drained. The pump is also designed to allow the indexing of the upper head casting in increments of 45 degrees. To do this, the 8 bolts clamping the motor together must be removed. The head casting can then be rotated to a position that facilitates the air and hydraulic connections. Once the head casting is in the desired position, be sure the bolt holes in the head casting align with the bolt holes in the bottom casting. Also, make sure the head and bottom castings are fully seated onto the air cylinder. If the castings are not fully seated, a soft mallet can be used to gently tap them into place. Once everything is in place, the 8 bolts can then be replaced, and the nuts can be threaded on until they just contact the casting flange. The bolts can then be tightened evenly a little at a time using an alternating star pattern. The final torque for these bolts is 19 ft-lbs.

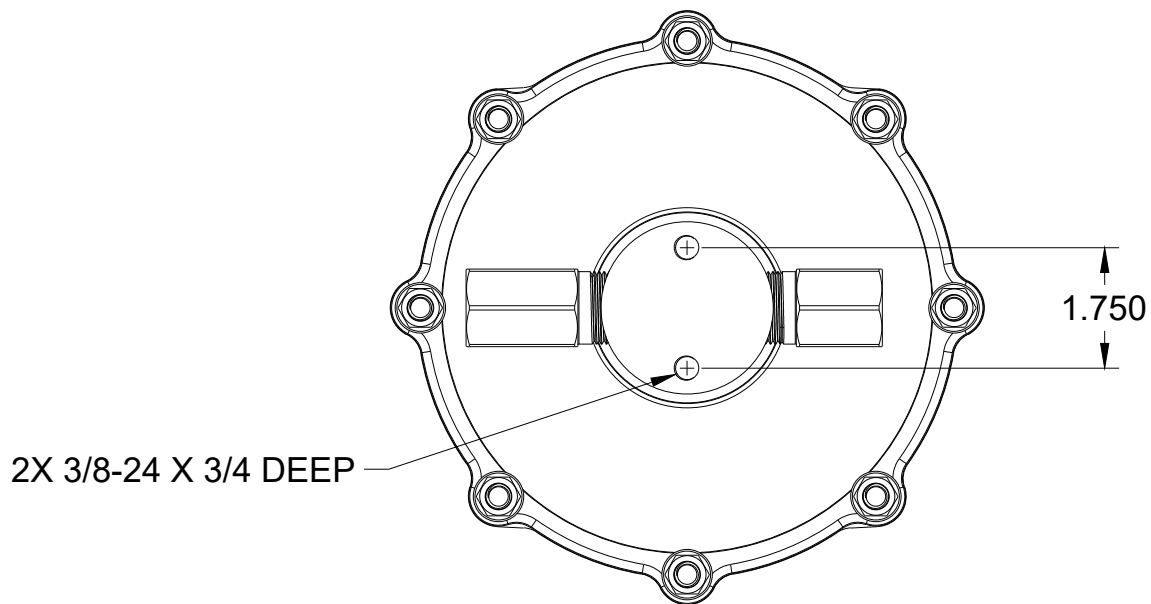

## 2. AIR INLET CONNECTION

The air inlet on the pump is a 1/2" NPT male port and is marked "**AIR IN**" on the head casting. An air filter/regulator/lubricator assembly and a shutoff valve are required to operate the pump. This "FRL" assembly should be located as close to the pump as possible and be connected in that order with the lubricator closest to the pump. The pump requires a 1/2" inside diameter supply line. Using a smaller airline will restrict the pump and could limit the capacity of the pump. At its maximum capacity the pump will utilize 56 scfm @ 100 psi air pressure. **DO NOT EXCEED 100 PSI AIR PRESSURE.**

## 3. AIR LUBRICATION

An air lubricator is required to operate the pump. A high-quality grade of petroleum based anti-wear ISO 15 hydraulic oil should be used. We recommend Mobil DTE 10 Excel 15, or any oil with equivalent anti-wear properties. If the recommended hydraulic oil is not available, a good quality air tool oil can also be used. For adequate lubrication of the pump, the lubricator should provide one drop of oil for every 20 strokes of the pump. Adjust the lubricator as necessary to achieve the proper amount of lubrication. Excessive lubrication, although not harmful to the pump, is wasteful and should be reduced. Lack of lubrication will lead to excessive wear on the internal components of the air system and significantly reduce the life of the pump.

## 4. AIR OUTLET CONNECTION

The air outlet on the pump is a 1" NPT male port and is marked "**AIR OUT**" on the head casting. A muffler is suggested to reduce noise during pump operation. Be sure the muffler is rated to at least 56 scfm air flow. Using a restrictive muffler will significantly reduce the capacity and efficiency of the pump. The exhaust air from the pump can also be piped away if no muffler is available or noise is not an issue. Be sure to use pipe or hose with a 1" inside diameter or larger for this. Any restriction on the outlet piping will also significantly reduce the capacity and efficiency of the pump.

## 5. FLUID INLET CONNECTION

The fluid inlet on the pump is a 1/2" NPT male port and is marked "**INLET**" on the inlet check valve. A clean supply of fluid is vital to the longevity of the hydraulic end. Grit or debris in the fluid supply will cause damage to the internal hydraulic components, significantly reducing the life of the pump. A dirty fluid supply can also cause a leak internally which can stop the pump from operating and reduce the efficiency and capacity of the pump. A filter should be used to increase the longevity of the hydraulic components. This filter should be at least 100 mesh (higher mesh equates to smaller openings in the filter). The connections on the filter should be at least 1/2" NPT to achieve maximum performance of the pump. A filter that is too restrictive or is clogged can result in improper function of the pump and can lead to cavitation within the pump. A fluid supply with a positive head is required to properly prime the pump and achieve maximum performance. To achieve this, the fluid level in the reservoir must be above the fluid inlet of the pump. This can also be achieved by providing a pressurized fluid supply (**NOT TO EXCEED 150 PSI**).

**WARNING: THIS PUMP IS DESIGNED TO PUMP EITHER WATER OR PETROLEUM BASED HYDRAULIC OIL. THIS IS SPECIFIED AT THE TIME OF ORDERING. THIS PUMP IS NOT GUARANTEED TO PUMP FLUIDS OTHER THAN THOSE SPECIFIED. PUMPING CORROSIVE FLUIDS WILL DETERIORATE THE INTERNAL SEALS AND/OR METAL COMPONENTS OF THE PUMP. CONTACT US FOR INFORMATION ON PUMPS DESIGNED FOR THESE SPECIAL FLUIDS.**

## 6. FLUID OUTLET CONNECTION

The fluid outlet on the pump is a 1/2" NPT male port and is marked “**OUTLET**” on the outlet check valve. Extra care should be taken when making connections on the outlet side of the pump to ensure proper sealing at high pressures.

**WARNING: ALL FITTINGS USED ON THE FLUID OUTLET SIDE OF THE PUMP MUST BE RATED TO AT LEAST 10,000 PSI WORKING PRESSURE.**

### TYPICAL CIRCUIT FOR INSTALLATION

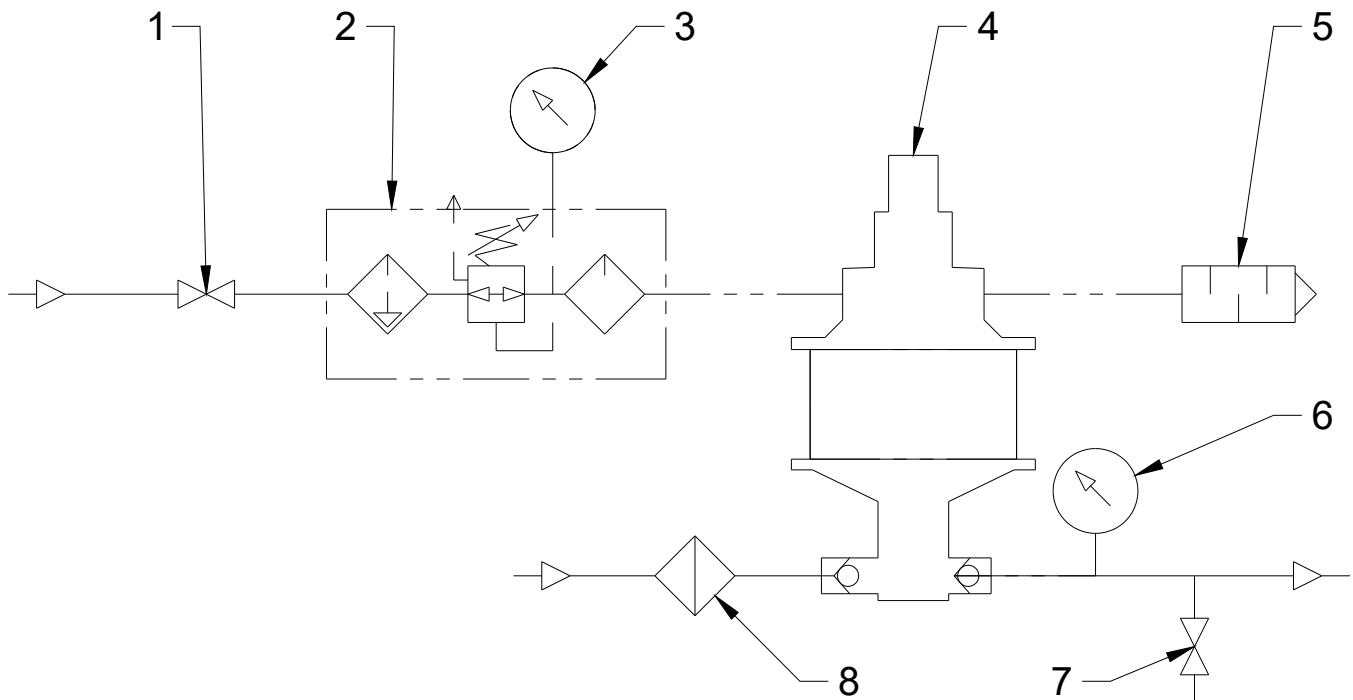

Item	Description
1	Air Shut-off Valve
2	“FRL” Assembly
3	Air Pressure Gauge
4	Pump
5	Exhaust Muffler
6	Hydraulic Pressure Gauge
7	Fluid Bleed Valve
8	Hydraulic Fluid Filter

# **PUMP OPERATION**

## **1. PUMP STARTUP**

- a) Fill the air lubricator with oil as recommended.
- b) Open the air pressure regulator fully (counterclockwise on most regulators) before opening the air supply valve to the pump.
- c) Open fluid supply valve to pump and open fluid bleed valve to allow fluid to flow through pump and bleed off any air in the fluid system.

**WARNING: BE SURE FLUID IS FLOWING THROUGH THE PUMP AND AIR IS BLED FROM THE FLUID SYSTEM BEFORE STARTING THE PUMP. RUNNING THE PUMP DRY WILL DAMAGE THE INTERNAL COMPONENTS AND REDUCE THE LIFE OF THE PUMP.**

- d) Close the bleed valve once all air has been bled from the fluid system. Inspect the fluid system for any obvious leaks.
- e) Slowly close the air pressure regulator (clockwise on most regulators) until the pump begins to cycle. The pump should start at about 10 to 15 psi of air pressure under normal conditions.
- f) While the pump is cycling, check the air lubricator to verify the proper amount of oil is being provided (One drop of oil for every 20 strokes of the pump).
- g) Adjust the air pressure regulator until the desired hydraulic pressure is attained.  
**DO NOT EXCEED 100 PSI AIR PRESSURE.**

## **2. TROUBLESHOOTING**

The pump has been tested and certified by the factory. If the pump does not function properly, the following items should be checked:

- a) Verify all connections to the pump are correct. Verify the air supply line is connected to the port marked “AIR IN”, and the fluid supply is connected to the port marked “INLET”.
- b) Verify that sufficient air pressure and flow are available to produce the desired pump output. An insufficient air supply can hinder the published performance data of the pump.
- c) Verify there is an adequate and unrestricted fluid supply, the fluid reservoir is full and/or the fluid supply reaches the pump.

After verifying the above, begin “Pump Startup” again. If the pump still does not function properly, contact the factory. Have the pump model number, serial number and a description of the problem ready.

# PI7000-01 AIR MOTOR ASSEMBLY

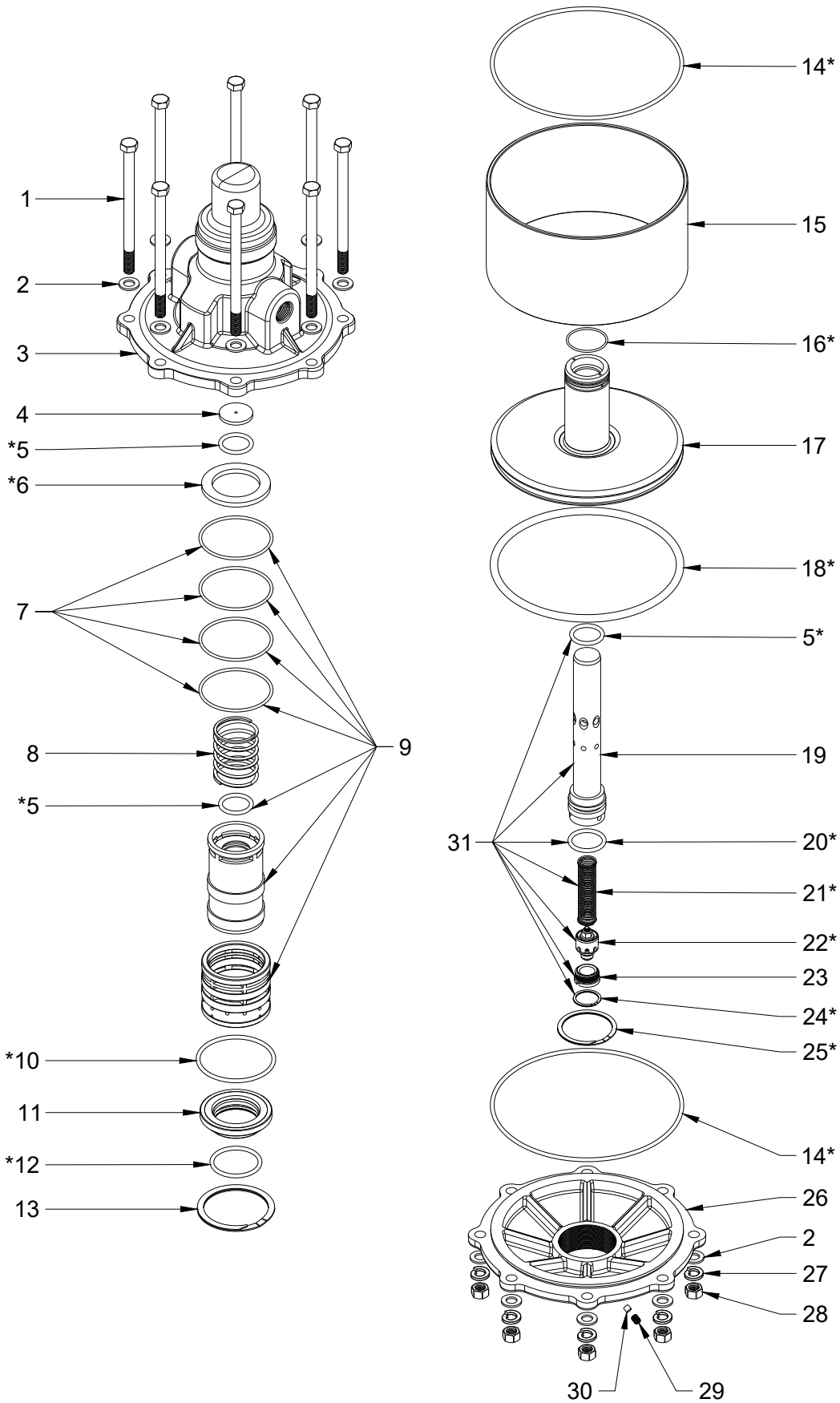

# PI7000-01 AIR MOTOR ASSEMBLY

Item	Part #	Description	Qty.
1	PI017	Bolt	8
2	PI024	Flat Washer	16
3	PI022	Head Casting	1
4	PI002	Bumper, Pilot Valve	1
5*	PI011	O-Ring	3
6*	PI015	Bumper, Slide Valve	1
7	PI021	O-Ring	4
8	PI005	Spring, Return	1
9	PI001	Slide Valve Assembly	1
10*	PI009	O-Ring	1
11	PI007	Bearing Assembly	1
12*	PI008	O-Ring	1
13	PI014	Retaining Ring, Head	1
14*	PI010	O-Ring	2
15	PI006	Air Cylinder	1
16*	PI019	O-Ring	1
17	PI004	Air Piston	1
18*	PI012	O-Ring	1
19	PI023	Pilot Valve Body	1
20*	PI029	O-Ring	1
21*	PI026	Spring, Pilot Valve	1
22*	PI025	Air Check Assembly	1
23	PI027	Seat	1
24*	PI030	Retaining Ring, Pilot Valve	1
25*	PI013	Retaining Ring, Air Piston	1
26	PI003	Bottom Casting	1
27	PI028	Lock Washer	8
28	PI016	Hex Nut	8
29	PI018	Set Screw	1
30	PI041	Plug	1
31	PI020	Pilot Valve Assembly	1
*	PI5050A	Air Motor Seal Kit (includes all items marked with asterisk)	1

# PI7000-01 HYDRAULIC END ASSEMBLY

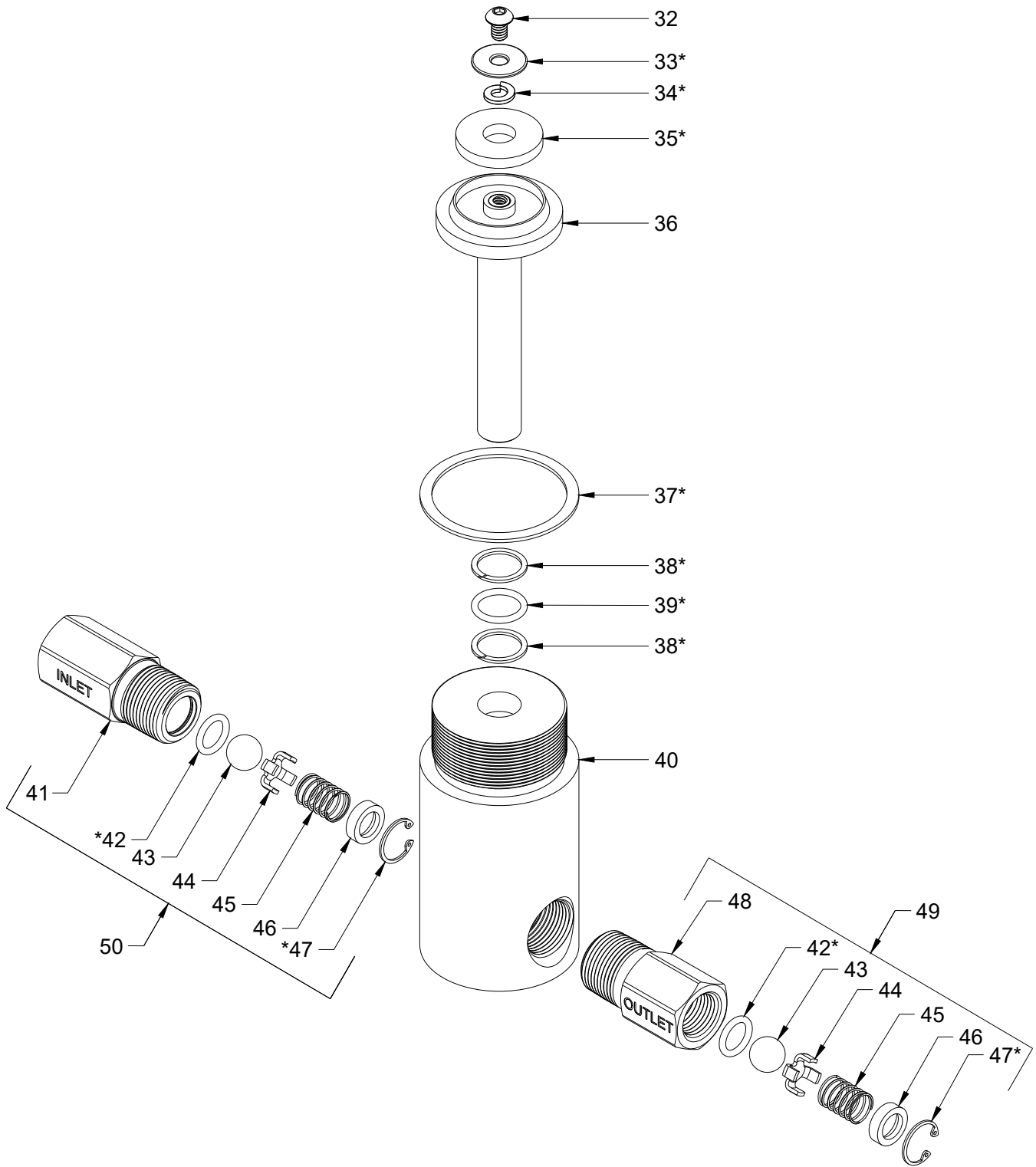



# PI7000-01 HYDRAULIC END ASSEMBLY

Item	Part #	Description	Qty.
32	PI5039	Screw, Hydraulic Piston	1
33*	PI5040	Flat Washer, Hydraulic Piston	1
34*	PI5041	Lock Washer, Hydraulic Piston	1
35*	PI5020	Bumper, Hydraulic Piston	1
36	PI5042	Hydraulic Piston, 95:1	1
37	PI5038	Hydraulic Piston Assembly, 95:1 (includes items 32 thru 36)	1
38*	PI5043	Gasket, Hydraulic Cylinder	1
39*	PI5026	Backup Ring	2
40*	PI5021	O-Ring	1
41	PI5047	Hydraulic Cylinder, 95:1	1
42	PI5057	Body, Inlet Check Valve	1
43*	PI5056	O-Ring	2
44	PI5055	Ball	2
45	PI5054	Ball Guide	2
46	PI5053	Spring	2
47	PI5052	Spring Guide	2
48*	PI5051	Retaining Ring	2
49	PI5066	Body, Outlet Check Valve	1
50	PI7000-223	Outlet Check Valve Assembly	1
51	PI7000-222	Inlet Check Valve Assembly	1
*	PI5050H	Hydraulic End Seal Kit (includes all items marked with asterisk)	1
	PI5050	PI5050A (Air Motor Seal Kit) + PI5050H (Hydraulic End Seal Kit)	1

# **TROUBLESHOOTING PUMP OPERATION**

## **1. Short stroking**

Pump appears to be running too fast, or the stroke is short and quick.

- a) A faulty Air Check Assembly (see “Pilot Valve Assembly Repair” below for replacement procedure)
- b) A clogged exhaust muffler, pipe, or tube – remove or replace the muffler, pipe, or tube.

## **2. Low or loss of pressure**

Pump does not produce the correct amount of pressure or pump will not hold pressure.

- a) Insufficient air supply – not enough air pressure supply, not enough air flow, or a faulty air pressure regulator (see “Air Inlet Connection” above for air supply requirements)
- b) Insufficient fluid supply – make sure fluid is able to flow through the pump and out of the fluid bleed valve before operating pump.
- c) The Hydraulic Check Valves are not sealing properly (see “Repairing or Replacing the Hydraulic Check Valves” below)
- d) The seal in the Hydraulic Cylinder is not sealing properly, which would also cause hydraulic fluid to appear in the air exhaust (see “Hydraulic Cylinder Seal Replacement” below)

## **3. Running erratically or jerky**

Pump does not run smoothly, pump strokes erratically or in a jerky motion.

- a) Insufficient air lubrication – not enough lubrication being delivered due to a misadjusted or faulty air lubricator. Adjust lubricator to deliver 1 drop of oil for every 20 strokes of the pump, or replace lubricator (see “Air Lubrication” above)
- b) Foreign matter, such as alkali, dirt, grit or chemicals with insufficient lubrication properties are present in the fluid supply. Normally a thorough cleaning of the Hydraulic Piston and Cylinder is sufficient to resolve this problem.
- c) If pump cycling motion is bad enough, internal components could be damaged. See “Servicing Instructions” below to disassemble the pump and replace the damaged components.

## **4. Excessive oil, water or other fluid in air exhaust**

An excessive amount of oil, water or other fluid is present in the air exhaust.

- a) Excessive air lubrication – an excess amount of lubrication being delivered due to a misadjusted or faulty air lubricator. Adjust lubricator to deliver 1 drop of oil for every 20 strokes of the pump, or replace lubricator (see “Air Lubrication” above)
- b) Insufficient air filtration – the air filter is inadequate or faulty. The bowl of the air filter must be emptied manually if not automatic unit. The bowl should also be removed and cleaned periodically. Replace the air filter if it is deemed inadequate or faulty (see “Air Inlet Connection” above)
- c) Damaged/worn seal in the Hydraulic Cylinder will cause the hydraulic fluid to leak into the Air Motor and come out of the air exhaust (see “Hydraulic Cylinder Seal Replacement” below)

# **SERVICING INSTRUCTIONS**

## **1. AIR MOTOR DISASSEMBLY**

- a) Remove the eight bolts that clamp the Air Cylinder (Item #15) between the Head Casting (Item #3) and the Bottom Casting (Item #26). Remove the Head Casting by tapping on a fitting screwed into either the “AIR IN” or “AIR OUT” ports with a soft hammer.

WARNING: When removing Retaining Rings, be careful not to damage the groove where it seats. Damage to the groove can cause other parts not to fit properly and/or cause burrs to form. These burrs can become loose inside the air motor and cause damage to the internal components.

- b) Remove the Air Piston (Item #17) from the Air Cylinder and separate the Air Cylinder from the Head Casting.
- c) Carefully remove the Retaining Ring (Item #25) from the bottom of the Air Piston and remove the Hydraulic Piston (Item #36). Push the Pilot Valve Assembly (Item #31) out through the bottom of the Air Piston.
- d) Carefully remove the Retaining Ring (Item #13) from the Head Casting. Remove the Bearing Assembly (Item #11) by pulling or carefully prying it out with a hammer handle or similar tool. The Bearing Assembly has a molded rubber seat and should be replaced if worn or damaged. The Slide Valve Piston (inner part of Item #9) may also be removed at this time. Be sure to pull the Slide Valve Piston straight out and do not force it. These parts have extremely close tolerances and can easily be lodged and/or damaged if any angular movement is used. The O-ring (Item #12) in the Bearing Assembly, the O-ring (Item #5) in the upper part of the Slide Valve Piston, and the O-ring (Item #20) on the Pilot Valve Assembly should be replaced even if no damage is present as they are especially important for maximum performance of the pump.
- e) The Slide Valve Bumper (Item #6) located in the Head Casting just above the Slide Valve Sleeve (outer part of Item #9) acts as a cushion and a seal for the Slide Valve Piston. This bumper should be replaced if it is worn or damaged.

WARNING: DO NOT remove the Slide Valve Sleeve from the Head Casting unless it is to be replaced. The Slide Valve Assembly is precision ground and honed to extremely close tolerances. The sleeve can easily be damaged when being removed from the Head Casting.

- f) If worn or damaged, the Slide Valve Piston and Sleeve are supplied as the Slide Valve Assembly (Item #9). The sleeve may be removed from the Head Casting using an internal puller engaged in the slots in the sleeve. Replace the 4 O-rings (included with a replacement Slide Valve Assembly) in the Head Casting that engage with the sleeve. Be sure to lubricate these O-rings and the outside of the sleeve with a suitable lubricant to avoid damage to the O-rings when installing the new Sleeve.
- g) Carefully reinsert the Slide Valve Piston into the Sleeve. Be sure to lubricate the O-ring located in the Piston (included with a replacement Slide Valve Assembly) and the outside of the Piston. DO NOT force these parts together. The Piston should slide somewhat easily into the Sleeve if done correctly.

## **2. PILOT VALVE ASSEMBLY REPAIR**

The Pilot Valve Assembly (Item #31) has an Air Check Assembly (Part #22) located in the lower end.

- a) Remove the Retaining Ring (Item #24) which locks the Valve Seat (Item #23) in place.
- b) Unscrew the Valve Seat with a spanner wrench. The Air Check Assembly and the Spring (Item #21) will then drop out and may be inspected for wear or damage.
- c) Replace the spring and worn parts as required.

## **3. HYDRAULIC CYLINDER SEAL REPLACEMENT**

To replace the seal in the hydraulic fluid end it is not necessary to disassemble the air motor.

- a) Remove all connections to the hydraulic fluid end.
- b) Loosen the Set Screw (Item #29) in the Bottom Casting (Item #26) and unscrew the Hydraulic Cylinder (Item #40) from the Bottom Casting. The Hydraulic Piston (Item #36) will stay connected to the air motor allowing the seal in the Hydraulic Cylinder to be replaced.
- c) Carefully remove the Backup Rings (Item #38) and the O-Ring (Item #39).
- d) When installing the new Backup Rings and O-Ring, be sure they are properly seated in the groove. Once seated, lubricate the new seal and the outside of the Hydraulic Piston.
- e) Replace the Hydraulic Cylinder Gasket (Item #37) if it is damaged.
- f) Carefully insert the Hydraulic Piston into the Hydraulic Cylinder and screw the Hydraulic Cylinder into the Bottom Casting. Tighten the Hydraulic Cylinder securely, then tighten the Set Screw (Item #29) in the Bottom Casting.

## **4. THE HYDRAULIC PISTON**

The Hydraulic Piston shaft is hard chrome plated and ground to close tolerance with the Hydraulic Cylinder. If the shaft shows any signs of damage (usually in the form of vertical scoring from debris in the hydraulic fluid), it should be replaced. The Hydraulic Piston has a Bumper (Item #35) in the head. Replace this bumper if it is damaged or worn. The Hydraulic Piston replacement is sold with the Bumper, Screw and washers.

- a) Remove the Screw (Item #32), Flat Washer (Item #33) and Lock Washer (Item #34), then remove the Bumper and replace.
- b) Apply blue threadlocker to the Screw threads and reinstall with Flat Washer and Lock Washer. Tighten the screw securely, but do not exceed 4 ft-lbs. of torque.

## **5. REPAIRING OR REPLACING THE HYDRAULIC CHECK VALVES**

The Hydraulic Check Valves are designed for long life utilizing an o-ring to provide a high-pressure seal. Dirt and grit in the fluid supply can deteriorate and damage this o-ring and reduce the ability of the check valve to seal.

- a) Remove the connection to the Check Valve and remove the Check Valve from the Hydraulic Cylinder.
- b) The Check Valve can now be replaced completely, or the internal components can be replaced to repair it. To repair the Check Valve, carefully remove the Retaining Ring (Item #47) from the end. The Spring Guide (Item #46), Spring (Item #45), Ball Guide (Item #44) and Ball (Item #43) should all drop out at this point.
- c) Carefully remove the O-Ring (Item #42) using a small pick, making sure to not damage the groove in which it sits.
- d) With the O-Ring removed, visually inspect the ball seat in the Check Valve for damage. If the seat is damaged the entire assembly should be replaced. If no damage is present, install the new O-ring into the groove.
- e) Check the rest of the components for damage and replace as necessary (it is recommended to replace the Ball when installing a new O-ring).
- f) Drop the Ball, Ball Guide, Spring and Spring Guide into the Check Valve and reinstall the Retaining Ring into the groove.
- g) Clean and apply thread sealing tape to the Check Valve threads and reinstall into the Hydraulic Cylinder. This is an NPT thread and requires a significant amount of torque to properly seal the joint. Reconnect any connections to the Check Valve.

## **6. REASSEMBLING THE PUMP**

Once all required repairs and inspection have been completed, the pump can be reassembled. During this process, be sure all components that operate in o-rings are free of debris or damage that may cause premature wear to the o-ring and cause the pump to malfunction. Inspect all o-ring and retaining ring grooves for debris or damage before reinstalling those items. Begin reassembly, making sure that all o-rings have not been damaged in reassembly and all retaining rings are properly seated.

**WARNING:** When reassembling the Air Motor, be sure the bolt holes in the head casting align with the bolt holes in the bottom casting. Also, make sure the head and bottom castings are fully seated onto the air cylinder. If the castings are not fully seated, a soft mallet can be used to gently tap them into place. Once everything is in place, the 8 bolts can then be replaced, and the nuts can be threaded on until they just contact the casting flange. The bolts can then be tightened evenly a little at a time using an alternating star pattern. The final torque for these bolts is 19 ft-lbs.