

WIDDER TOOLS



20265 24" Pneumatic Jet Fan



PRODUCT INFORMATION AND OPERATING INSTRUCTIONS

Description: The **20265** 24" Pneumatic Jet Fan is a flange mounted air powered blower. The heavy-duty construction incorporates the industry standard API flange connection on both ends. The air inlet fitting sits below the outer flange to allow easy rolling movement of the fan without damaging the inlet fitting.

Specifications: 16,100 CFM air movement @ 100 PSI and 335 CFM compressed air input
3/4" NPT inlet

Dimensions: 32" Diameter x 13" Depth

Weight: 142 lbs.

**IMPORTANT: READ MANUAL CAREFULLY BEFORE OPERATING THIS TOOL.
FOLLOW ALL SAFETY PRECAUTIONS LISTED AND ALL OSHA REGULATIONS
PERTAINING TO THIS TOOL.**

SAFETY PRECAUTIONS:

Warning: When using air tools, basic safety precautions should always be followed to reduce the risk of injury, including the following:

1. Must be used with eye and ear protection.
2. Be sure all guards are securely in place before operating.
3. Do not attach to air supply without having unit securely bolted in place or fastened down
4. This unit is designed to use with compressed air only; do not use with mixed gases or steam
5. Do not exceed 110 PSI input
6. Unit must be grounded before use.
7. Operator is responsible for all decisions and calculations regarding air movement, blower capacity, and evacuation requirements. This unit does not address any requirements regarding breathing apparatus. Unit output drops quickly in the presence of negative relative pressure between the inlet side and outlet side.

OPERATING INSTRUCTIONS:

1. Mount unit using mounting slots. Be sure unit is secure and the arrows indicating airflow direction are correctly oriented.
2. Connect grounding clamp to a true ground; check ground clamp wire for good attachment to unit frame.
3. Connect $\frac{3}{4}$ NPT input line.
4. Apply direct line pressure of up to 110 PSI.

De-energize and disconnect air power before attempting to move, adjust, or service unit.

WIDDER CAT 5 24" Air Mover Fan #20265

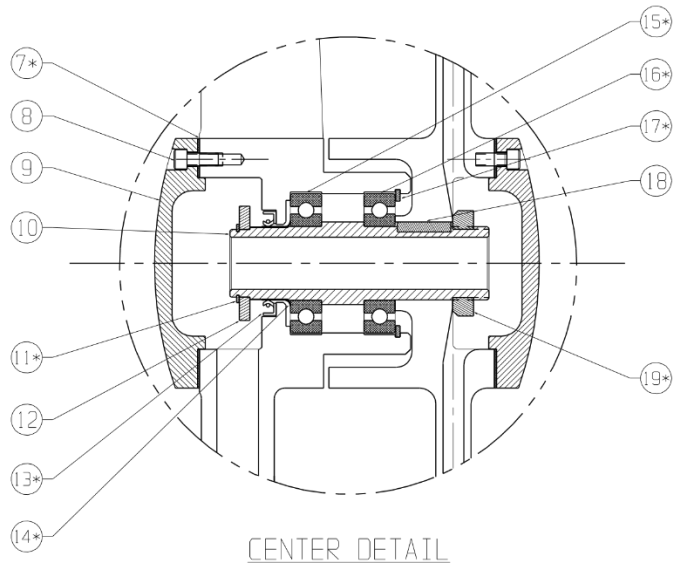
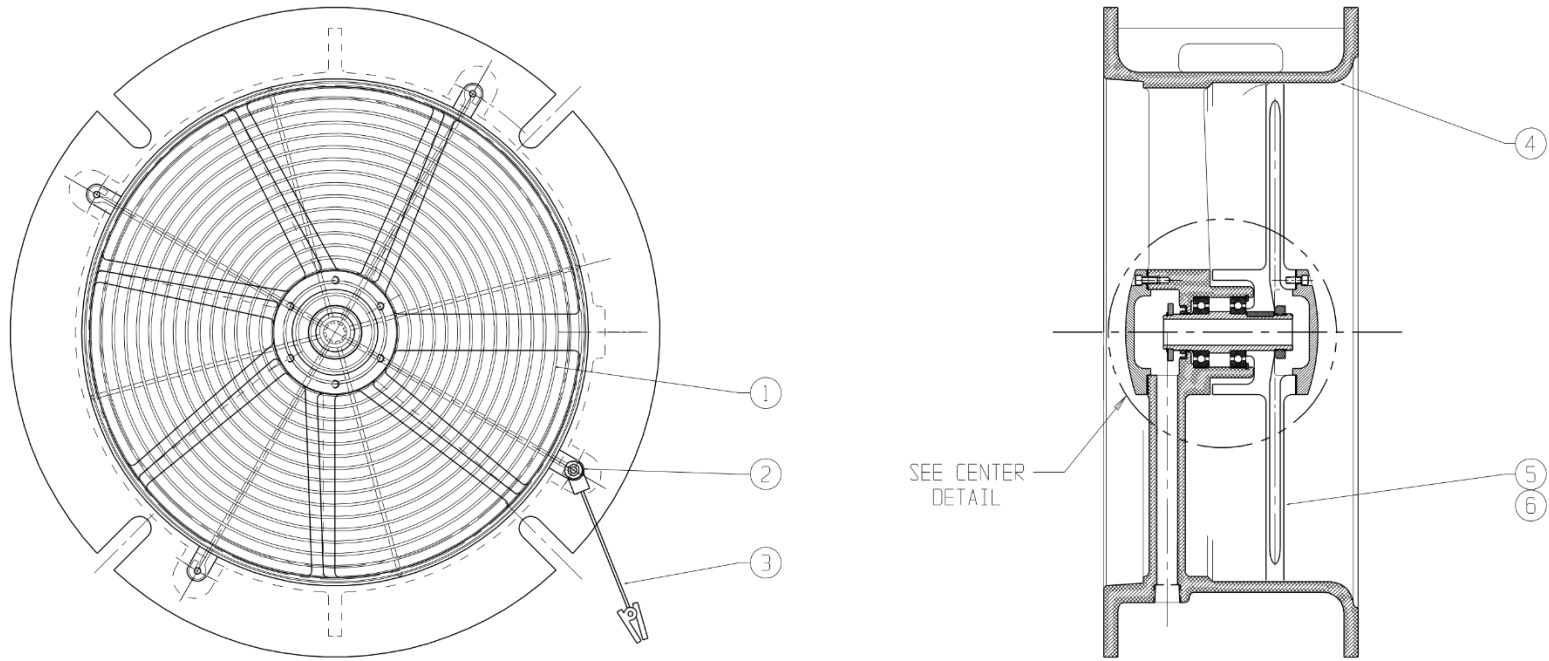

* Part of item
20 Repair Kit

WIDDER CAT 5 24" Air Mover Fan #20265

Item #	Customer #	Description	Qty/Unit
1	20224	Screen	2
2	20221	Screen Fastener Set	8
3	20203	Ground Clip Assy	1
4	20222	Body	1
5	20223	Fan Blade Assy	1
6	20206	Venturi Tip	2
7	20207	Gasket	2
8	20208	End Cap Bolts	12
9	20209	End Cap	2
10	20210	Shaft	1
11	20211	Retaining Ring, Shaft	1
12	20212	Shaft Retainer	1
13	20213	Shaft Seal	1
14	20214	Wear Sleeve	1
15	20215	Tolerance Ring	2
16	20216	Ball Bearing	2
17	20217	Retaining Ring, Housing	1
18	20218	Key	1
19	20219	Shaft Nut	1
20	20020	Fan Repair Kit, Includes Items: 7,11,13,14,15,16,17,19	